

# FIORDIPESCO NOTTE







**LE FABLIER**

*Valori per sempre*





E nel mezzo del giardino  
un albero,  
un lampo roseo di fiori:  
il pesco,  
sbocciato grande su tutta la collina,  
re della futura primavera...

*And in the middle of the garden  
A tree,  
A rosy flash of flowers:  
The peach tree,  
In full bloom all over the hill  
King of the coming spring...*



# Custodi della tradizione

**La scelta del legno** Forte, generoso, ricco di storia e di tradizione. Niente è più prezioso, e più caldo, del legno. La collezione “Fiordipesco” nasce da questo calore, dalla solidità delle tavole che gli specialisti Le Fablier selezionano con cura ed esperienza. Per scegliere solo le essenze più pregiate, per verificarne il taglio migliore, per controllare la perfetta stagionatura. Nel pieno rispetto della natura e della bellezza delle essenze tradizionali.

**Le lavorazioni** Di maestro in maestro, di generazione in generazione, la nobile arte del legno trova in Le Fablier un appassionato custode. Erede di questa antica arte, ne rispetta i segreti e i dettami, perché ogni lavorazione venga eseguita solo secondo la migliore tradizione d'origine. Dall'incastro a coda di rondine all'intelaiatura di schiene e cassetti, dai rilievi in legno massiccio ai particolari rifiniti a mano. Un'arte che nasce dal tempo per sfidarlo, e per rimanere per sempre impressa nella memoria di chi la possiede con la stessa forza e lo stesso calore del fuoco. Proprio come il marchio a fuoco che sigla e distingue ogni singolo pezzo Le Fablier.

**I segreti** Pensieri, ricordi, sensazioni. Ci sono cose che è bello ritrovare e proteggere. Cose che non amano imporsi, ma preferiscono restare serbate in luoghi creati per mantenerne il fascino. Cassetti a scomparsa, piccoli angoli nascosti, vani inattesi. I mobili Le Fablier celano i loro segreti, custodi di amuleti misteriosi raccolti in viaggi di terre lontane. Perché chi possiede quei mobili, possa trasformarli in emozioni.

**Le finiture** La più alta perfezione è nei particolari, la bellezza più completa è nei dettagli. Soprattutto in un mobile che deve saperci parlare di eleganza, ogni giorno. Ecco perché dai rilievi più ricercati agli intrecci più pregiati, ogni piccola finitura dei mobili Le Fablier viene studiata per verificarne l'esatta coerenza stilistica, le uniformità di stile, e l'omogeneità di ispirazione tra il dettaglio e il suo contesto d'origine. E quello che il tempo ci restituisce è solo realtà.

**La lucidatura** La bellezza non è mai soltanto fatta di sguardi. È nei profumi, nelle sensazioni, nel piacere tattile di superfici da sfiorare. Per questo, la bellezza di ogni mobile Le Fablier viene completata da un antico rito: la lucidatura eseguita seguendo la più rigorosa tradizione, che si conclude con la stesura manuale della cera vergine d'api. Un fascino caldo e brillante che l'esperto lucidatore sa esaltare, e che può essere rinnovato ogni giorno con un semplice panno di lana. Natura, tradizione, cultura. E il legno migliore, quasi avesse imprigionata dentro di sé la luce del sole, sembra, d'improvviso restituirla.

**La ricerca stilistica** Ogni mobile Le Fablier ha come più grande amico il tempo. Per questo ama conoscerlo e rispettarlo e custodirne la storia. Per questo ogni creazione nasce solo da disegni e progetti che seguono precisi riferimenti delle più importanti tradizioni stilistiche dei paesi d'origine. Esperti disegnatori, guidano i migliori falegnami nella realizzazione degli arredi che dovranno saper intendere e prevedere le esigenze di una casa in continua evoluzione. “Fiordipesco” nasce per offrire la soluzione più consona e personalizzata a chi ama vivere nella propria casa in un armonioso equilibrio di bellezza e funzionalità. Ogni momento del passato in cui l'uomo, guardando alla natura, ha ritrovato equilibrio, gusto serenità e poesia, diventa la nostra ispirazione e la nostra vocazione. Per ritrovare il fascino di atmosfere calde e raffinate, con le arti e i segreti del più antico artigianato. Per continuare a emozionare chi, quando sceglie di abitare lo stile, sa che il solo sentiero da imboccare è quello del ritorno.





# Guardians of tradition

**The choice of the wood** Strong, generous, rich in history and tradition. Nothing is finer or warmer than wood. The 'Fiordipesco' collection comes out of this warmth and the solidity of the wood boards that Le Fablier's professionals have carefully and expertly selected. They choose the finest woods, ensure the best cut and check for optimal seasoning. All with complete respect for the nature and beauty of traditional woods.

**Crafting** Throughout the generations, from master to master, the noble art of wood-working has found a devoted guardian in Le Fablier. As the heir of this ancient art, it respects its secrets and principles to craft each piece exclusively in keeping with the finest and oldest traditions, from dovetail joints to the framing of backs and drawers, from the profiled details in solid wood to the hand-finished carving. These pieces of art come out of history to become timeless and be emblazoned in the minds of their owners with the very strength and heat of fire. Just like the firebrand that marks and distinguishes every single Le Fablier piece.

**The secrets** Thoughts, memories and feelings. There are some things that it is good to recover and protect. These things do not like to assert themselves, preferring to stay stored in places created to preserve their wonder. Concealed drawers, hidden little corners, unexpected compartments. Le Fablier's furniture pieces hide their secrets like faithful guardians of mysterious charms found in remote lands. And the owners of these pieces can turn these moments into the emotions they hold.

**The finishing details** The highest perfection is in the specifics. The most complete beauty is in the details. Especially in a piece of furniture that must express the grace and elegance every day of the year. This is why every last finishing detail of Le Fablier furniture, from the most elegant profiled details to the most precious weaving, is designed to ensure its absolute historic accuracy, uniformity of style and match the inspiration of every detail with its original context. What time returns to us is simply reality.

**Polishing** Beauty is never just what you see with your eyes. It is the scents, the feelings and the tactile pleasure of the surfaces to be caressed. This is why the beauty of each Le Fablier piece is completed by an old ritual: polishing executed following the most rigorous traditional methods and completed with a manual application of pure beeswax. The master polisher knows how to exalt this warm, shining beauty that can be renewed every day with a simple wool cloth. Nature, tradition and culture. It is as if the finest wood had captured the light of the sun inside itself and suddenly decides to let it out.

**Stylistic research** Every Le Fablier piece's best friend is time. This means that it wants to know time, respect it and guard its stories. This is why each creation is born exclusively of designs that keep to specific references from the most important stylistic traditions of the countries of origin. Master designers guide the best carpenters in creating furniture that must be able to understand and anticipate the needs of homes that are always adapting. The 'Fiordipesco' collection is intended to offer the perfect, customized solution for those who wish to live in their homes amidst a harmonious balance of beauty, functionality and exotic feeling. Every moment in history in which someone has looked to nature to find balance, taste, serenity and poetry has become our inspiration and our vocation to rediscover the beauty of warm atmospheres with the secrets and the arts of the most ancient craftsmanship. And to continue to move those who choose to live in a style and know that the only path to take is the one back.











516 Sweet - Letto traforato  
184 x 224 x 109  
515 Diamond - Comò  
135 x 54 x 99  
512 Glory - Comodino  
57 x 36 x 65





















556 Grenat - Letto con bassorilievo  
184 x 224 x 109

















511 King - Comò ribalta  
135 x 54 x 105













513 Star - Specchiera  
100 x 3 x 68





20 515 Diamond - Comò  
135 x 54 x 99









Eppure, in un bel dì d'Aprile,  
sopra quel nero vidi, roseo, fresco,  
vivo, dal muro sporgere un sottile  
ramo di pesco.

*However, in an April sunny day ,  
Above that black I saw  
Rosy, fresh, lively  
From the wall  
A peach tree branch  
Was jutting out.*

*G.Pascoli*

















558 Royal - Letto con gambe a cipolla  
178 x 240 x 108

559 Rich - Comodino con gambe a cipolla  
64 x 38 x 57





561 Prince - Comò con gambe a cipolla  
140 x 52 x 98









561 Prince - Comò con gambe a cipolla  
140 x 52 x 98













559 Rich - Comodino con gambe a cipolla  
64 x 38 x 57





540 Gem - Tavolino rotondo con ruote  
Ø 52 x 63



Ogni fiore è un'anima  
che sboccia nella natura.

*Each flower is a soul  
That blooms in nature.*

*Gérard de Nerval (1808-18)*









538 Honey - Ovalino con sedia  
101 x 61 x 77 (sedia 57 x 48 x 70)









550 Lady - Cassetiera  
54 x 44 x 141









517 Elegant - Armadio 3 ante scorrevoli  
293 x 69 x 250









517 Elegant - Armadio 3 ante scorrevoli  
(anta centrale con specchio a fiori)  
293 x 69 x 250

517 Elegant - Armadio 3 ante scorrevoli  
(ante con inserto foglia oro)  
293 x 69 x 250





517 Elegant - Armadio 3 ante scorrevoli  
(ante laterali con pizzo)  
293 x 69 x 250



















**ABACO**





561 Prince - Comò con gambe a cipolla  
 561 Prince - Chest of drawers  
 140 x 52 x 98



515 Diamond - Comò  
 515 Diamond - Chest of drawers  
 135 x 54 x 99



511 King - Comò ribalta  
 511 King - Openable chest of drawers  
 135 x 54 x 105



512 Glory - Comodino  
 512 Glory - Bedside table  
 57 x 36 x 65



559 Rich - Comodino con gambe a cipolla  
 559 Rich - Bedside table  
 64 x 38 x 57

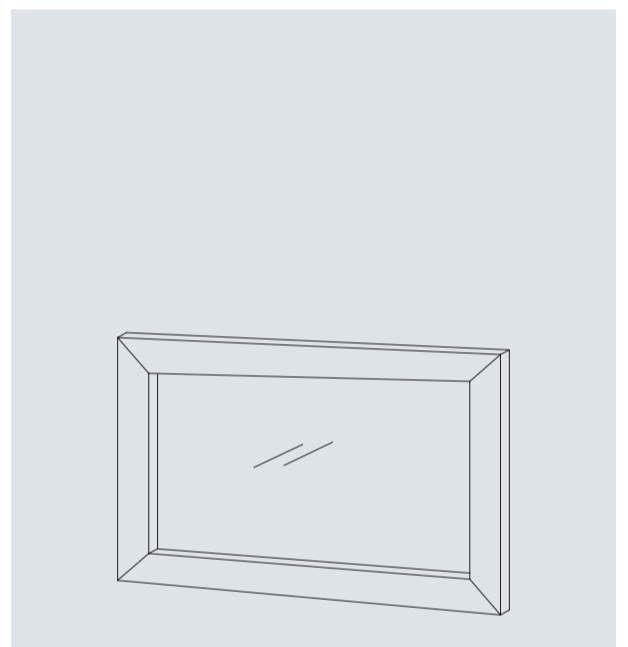

513 Star - Specchiera  
 513 Star - Mirror  
 100 x 3 x 68

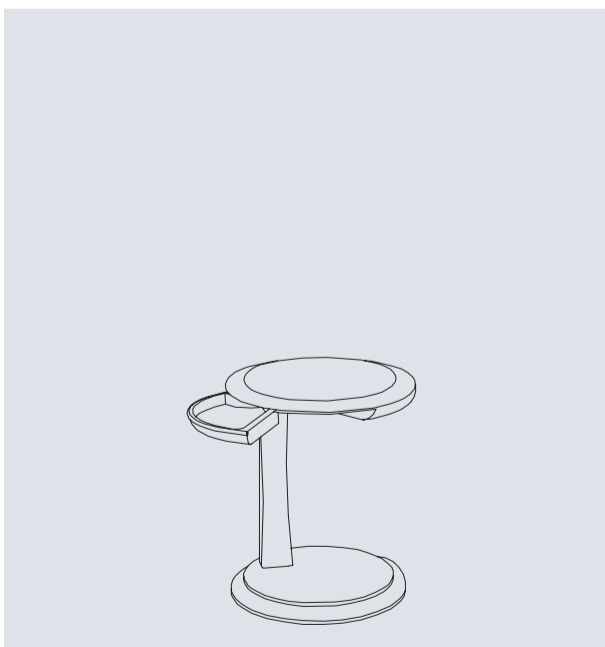

540 Gem - Tavolino rotondo con ruote  
 540 Gem - Round small table with castors  
 Ø 52 x 63



550 Lady - Cassettiera  
 550 Lady - Chest of drawers  
 54 x 44 x 141



538 Honey - Ovalino con sedia  
 538 Honey - Oval table with chair  
 101 x 61 x 77 (sedia 57 x 48 x 70)





516 Sweet - Letto traforato  
 516 Sweet - Fretwork bed  
 184 x 224 x 109



556 Grenat - Letto con bassorilievo  
 556 Grenat - Bed with panel of low/high relief  
 184 x 224 x 109



558 Royal - Letto con gambe a cipolla  
 558 Royal - Bed  
 178 x 240 x 108

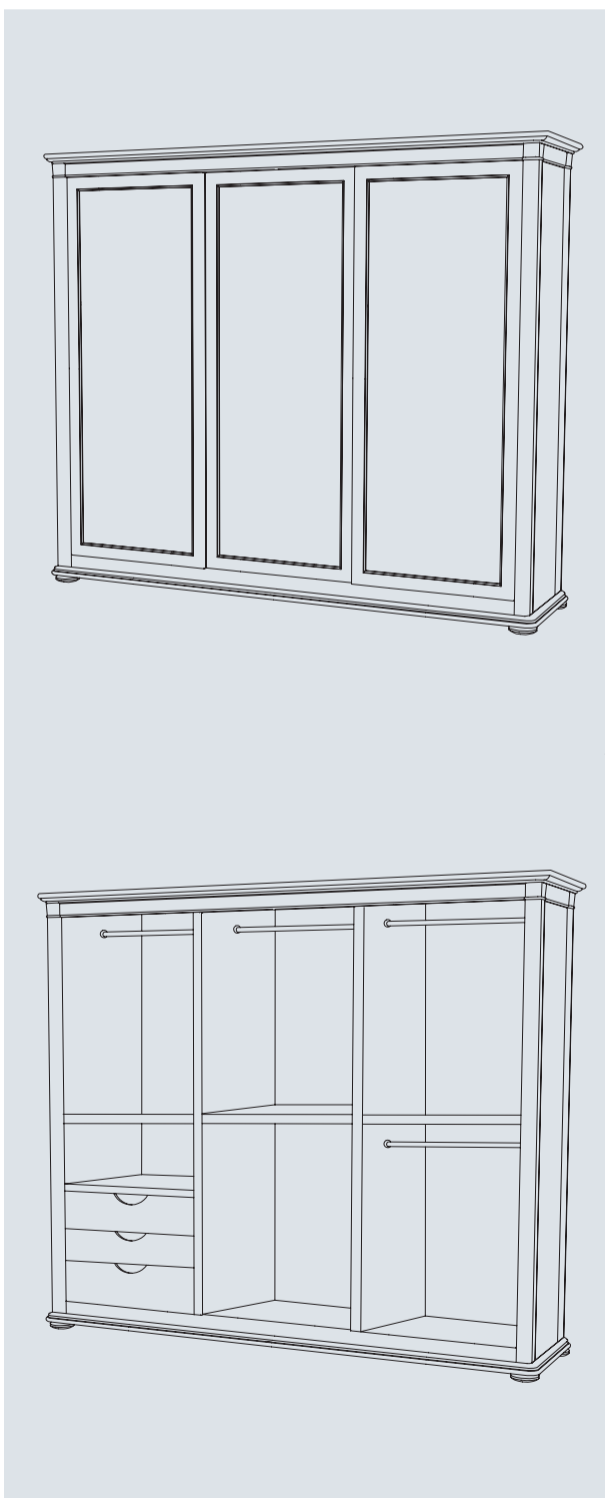

517 Elegant - Armadio 3 ante scorrevoli  
 517 Elegant - 3 sliding doors wardrobe  
 293 x 69 x 250

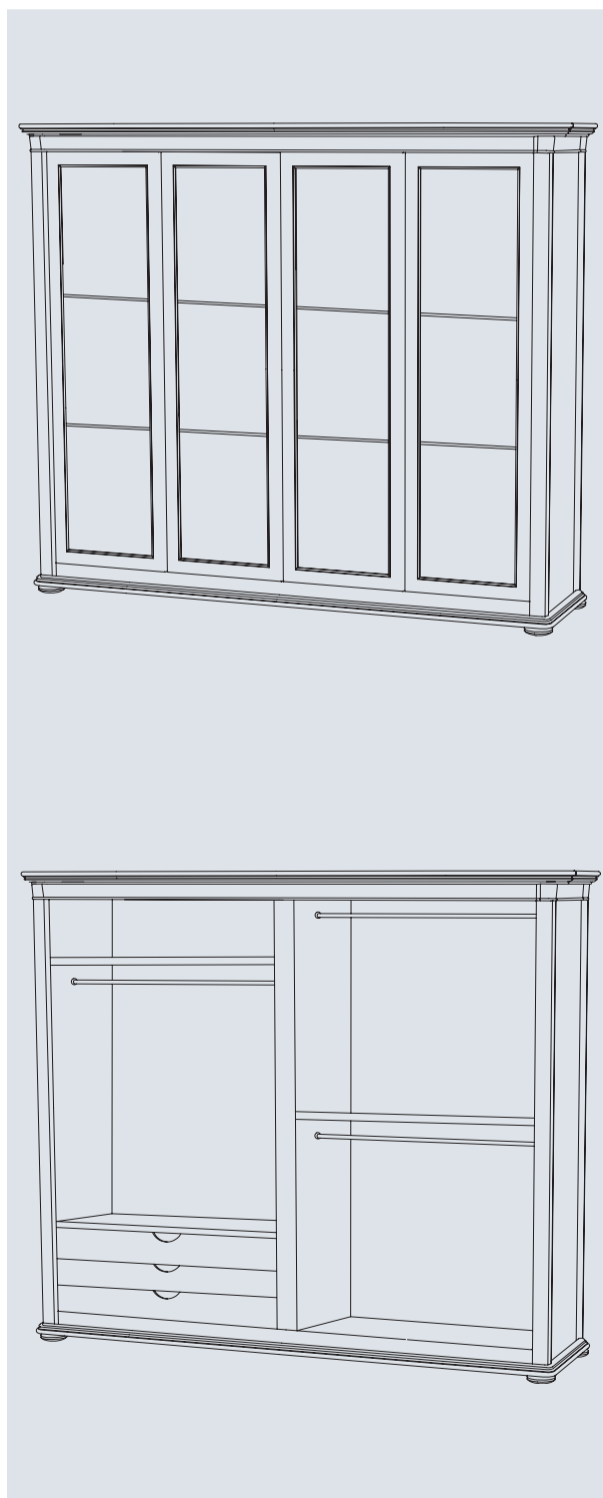

514 Simphonie - Armadio 4 ante  
 514 Sinphonie - 4 doors wardrobe  
 293 x 67 x 250



**Le Fablier SpA**

via del Lavoro, 2  
37067 Valeggio sul Mincio - Verona  
tel +39 045 6372000  
fax +39 045 6372001  
www.lefablier.com  
info@lefablier.it

**Fiordipesco notte**

design

**Arch. Giulio Manzoni**

in collaborazione con/  
in collaboration with

**Le Fablier S.p.A.**

ufficio ricerca e sviluppo/  
R&D office

graphic design

**Francesca Meneguzzi**

fotografia/

photography

**Mauro Negro**

assistenti alla fotografia/

photography assistants

**Marzio De Santis**

stylist

**Vanna Bellazzi**

coordinamento/

coordination

**Paola Storace**

stampa/

print

**OGM**

Grazie a/

Thanks to

Raro26 - oggettistica

Armando Fattolini - quadri

Lorenzo Mazza - quadri

Andrea Martiradonna - fotografie

Tisca - tappeti

Lampade Luci e Forme

Le Fablier - (VR)

edizione – Settembre 2009

Il catalogo è di proprietà esclusiva di  
Le Fablier S.p.A. – Tutti i diritti sono riservati.  
È vietata ogni forma di riproduzione anche  
parziale.

*This catalogue is of exclusive property of  
Le Fablier S.p.A. – All right are reserved.*

*Any form of total or partial reproduction of the  
catalogue is strictly forbidden.*

Il marchio e il logo “Le Fablier – valori per  
sempre” sono depositati e registrati.

*The “Le Fablier – valori per sempre” brand  
and logo are filed and registered.*

La stampa tipografica non sempre riproduce  
fedelmente le tinte degli originali.

*The printing process do not always permit a  
faithful reproduction of tones of originals.*

Le Fablier si riserva la facoltà di apportare in  
qualsiasi momento modifiche tecniche e  
dimensionali ai modelli, anche senza preavviso.

*Le Fablier reserves the right to change, in any  
time and without prior warning, the technical  
specifications and dimensions of the articles.*







